

PRODUCT DATA SHEET

Microwave Level Gauge

MRG-10



TOKYO
KEIKI

TOKYO KEIKI INC.

Microwave Level Gauge MRG-10



1. Advanced performance

The measuring principle is based on Time Flight impulse Radar technology that uses very short pulses.

- Non contact measuring
- Non mechanical moving parts
- High reliability, Easy maintenance
- High sensitivity
- Density, Pressure and Temperature independent

- Loop Power System (2-wire)
- 4-20mA output and HART output integrated
- Wide antenna range
- Interactive Windows-based setup software
- Built-in display/ keyboard

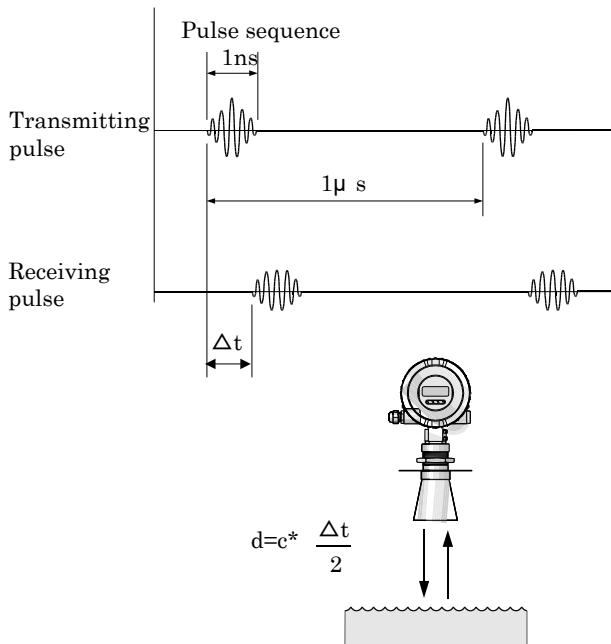

2. Features

1) Principle

Time Flight Impulse Radar Technology

2) Wide Measuring Range

Up to 20m Max.

3) Variety of Antennas

- 4inch Cone Antenna / 6inch Cone Antenna
- 8inch Cone Antenna
- PFA Rod Antenna (Long/Short inactive)

4) Easy Configuration

- Menu driven 4-keys input
- Graphical HART Configuration

3. Measuring principle

MRG-10 measures liquid levels by transmitting low energy radar pulses towards the liquid surface and receiving the radar echoes. The travel time for the radar pulse is proportional to the distance between the gauge and the surface.

Upon reception, microprocessors and intelligent software in the gauge head analyze the echoes and transform them into level output data.

The radar pulse is virtually unaffected by the tank content and atmosphere, temperature or pressure. Thus, radar measurement is proven to be the most reliable gauging method in most applications. Furthermore, maintenance requirements are in fact zero that as no part of the gauge is in physical contact with liquid.

All this makes MRG-10 very well suited for storage and buffer tanks in the chemical and water industry.

4. Applications

MRG-10 is appropriate for calm surface liquid. If you intend to use MRG-10 to measuring turbulence surface liquid, you had better to use still pipe in order to keep calm surface.

MRG-10 is appropriate for storage tanks or buffer tanks that they have relatively calm surface.

- Chemical and petroleum
- Pharmacy
- Food and beverage

Also it will be available in

- Water industrial such as river intake gate,
- Water supply,
- Sewage water treatment plant
- Hydraulic power station.

If you intend to use MRG-10 to measuring turbulence surface liquid, you had better to use still pipe in order to keep calm surface. Refer right figure.

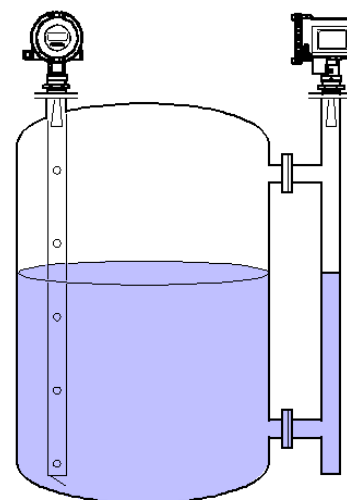
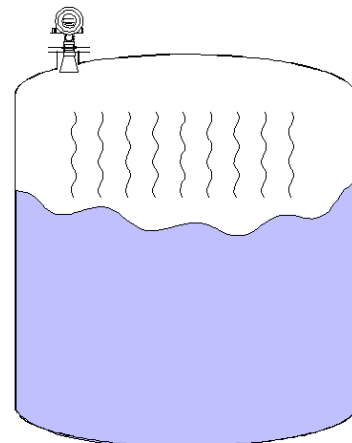
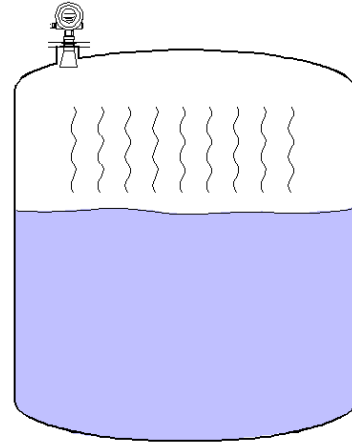

5. System

MRG-10 uses 2-wire system, which means both signal and power are available on same wiring. MRG-10 is certified as intrinsically safety instrument, then if you intend to use it in hazard area, intrinsically safety isolator should be used.

All of data is displayed by 5-digit LCD display on main body and changed items by 4 configuration buttons easily. Also it is possible to operate Interactive Windows-based setup software on PC.

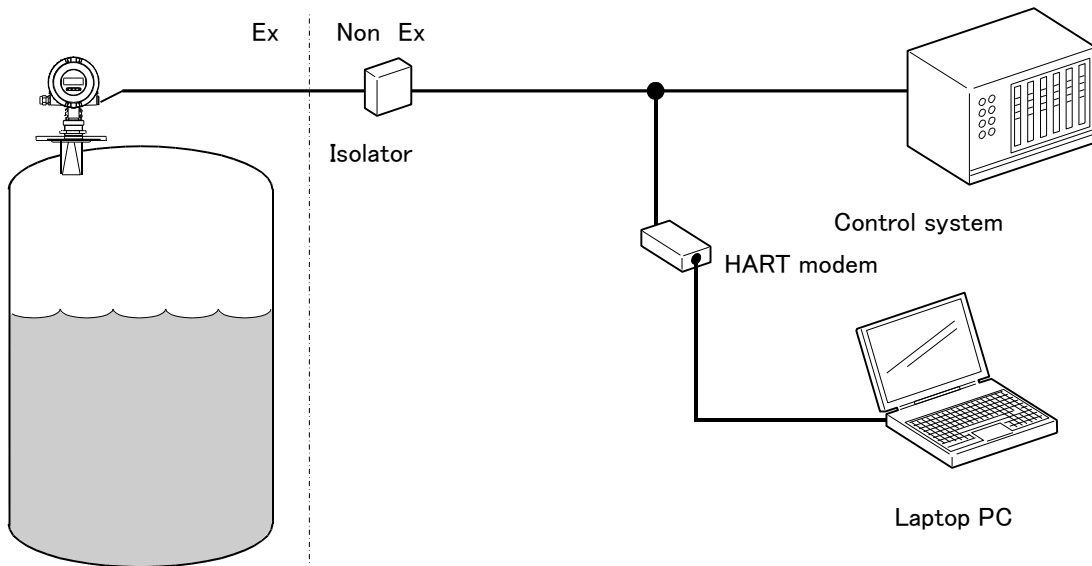
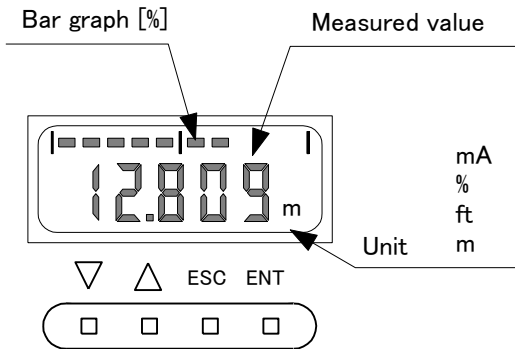

6. Measuring

Measuring performance will be decided by products nature (dielectric constant), surface conditions and antenna size.

In generally, the liquid, which has high dielectric constant number such as water, is easily to measure, and calm surface liquid is the same. On the contrary, low dielectric constant liquid, turbulence surface or forming surface and dirty antenna conditions are relatively difficult to measure. Even so if you choose right antenna, it is possible to measure in most of case.

Below table and graphs show suitable antenna, products and range.

| Type | Antenna | Targeting |
|----------------|----------------------|------------------|
| MRG-10A-5T0H | 4",6",8" Cone | Tank application |
| MRG-10A-5T0R-S | Rod antenna short | Low tank nozzle |
| MRG-10A-5T0R-L | Rod antenna long | High tank nozzle |

Almost all of liquid may be classified as below 3 types.

- a: Oil, Hydraulic carbon, Mainly petroleum industry ($\epsilon r=1.9\sim 4.0$)
- b: Alcohol, Acid ($\epsilon r=4.0\sim 10$)
- c: Water base liquid ($\epsilon r > 10$)

Antenna Measuring Distance (reference)

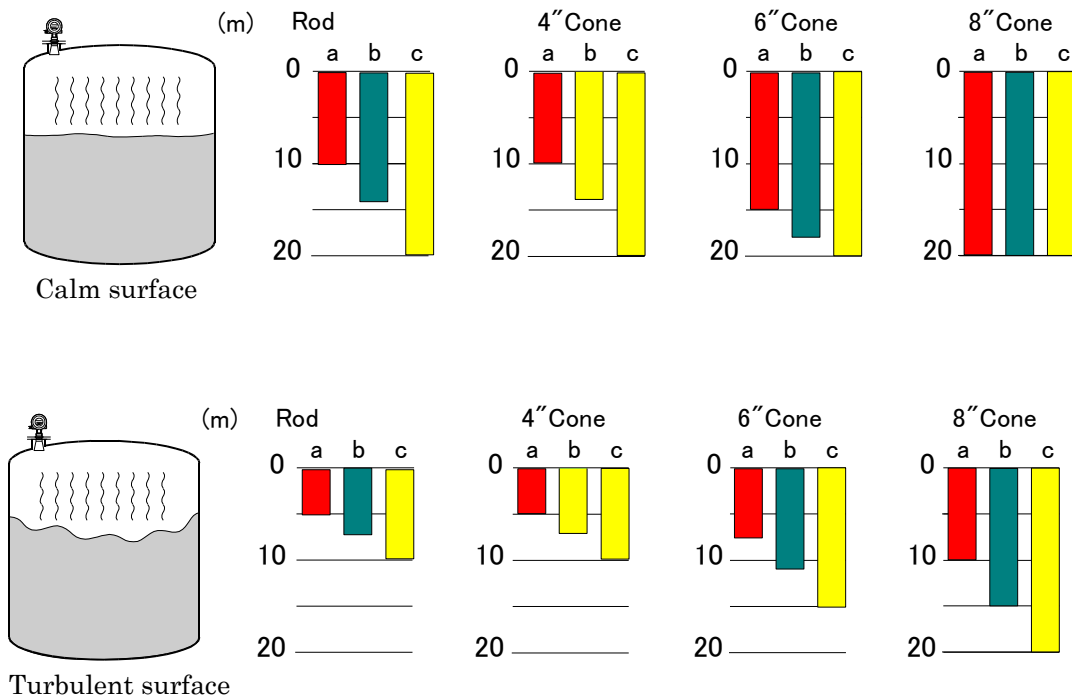

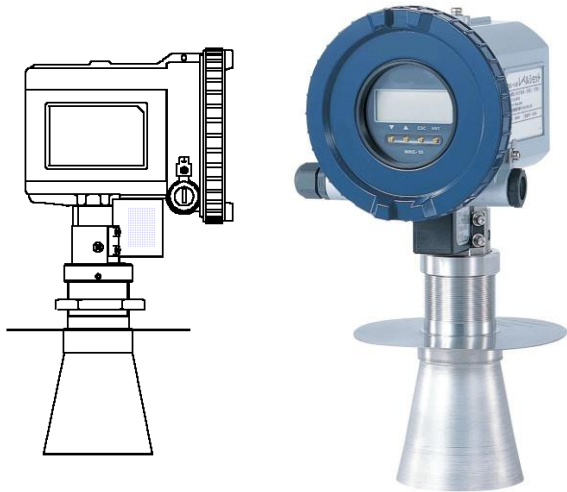

7. Antenna type

Antenna is only a part, which is exposed in tank inside, and you should choose proper antenna that suits to your demand.

7-1. Cone antenna

Cone antenna is available for both original tank or vessel and pipe installation.

The size of antenna are extending from 4 inch to 8 inch, and the only materials which is exposed in tank inside are consisted of SUS-316L and PTFE sealing and O rings.

Thanks to MRG-10 unique flange clamp solution, you can use your existing flange as process connection.

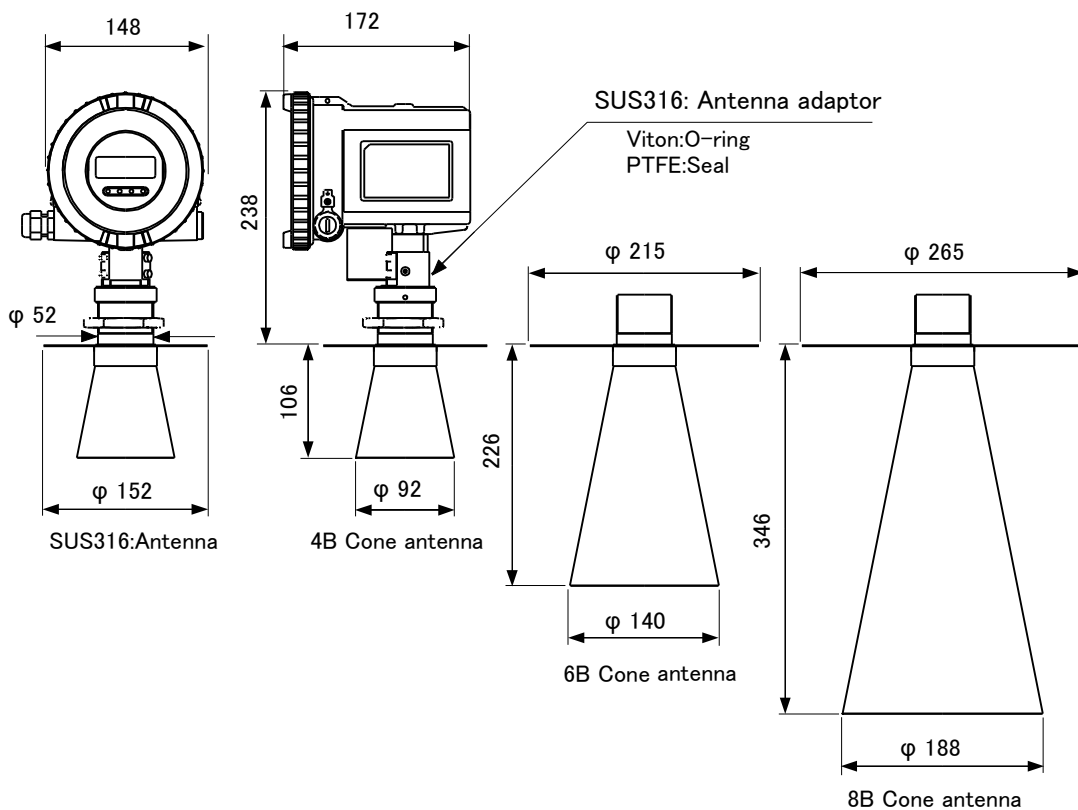

7-2. Rod antenna

The Rod antenna is made of Teflon (PFA) and stainless steel, which makes it easy to clean and resistant to aggressive chemicals and conditions. It has inactive length of 100mm and 250mm to ensure that measurements are unaffected by the mounting nozzle or thick flower.

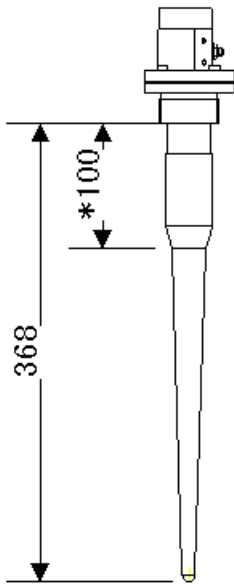
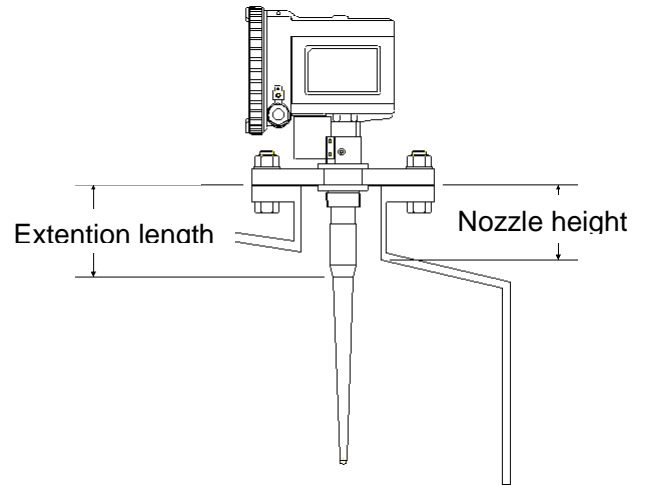

*Extension

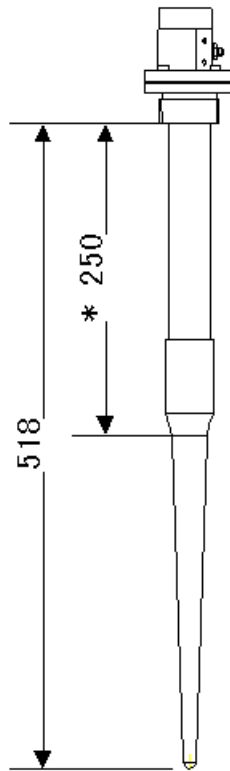

8. Mechanical Installation

MRG-10 shall be mounted on tank nozzle or pipe easily. To ensure performance you should install gauge properly as bellow.

Antenna should be kept horizontally. Inside of microwave transmitting area might be clear.

Set the gauge to keep away from tank wall as recommended dimension in the measuring ranges. To choose bigger size antenna as you can because big size antenna will be better to gain weak microwave echo in bad conditions.

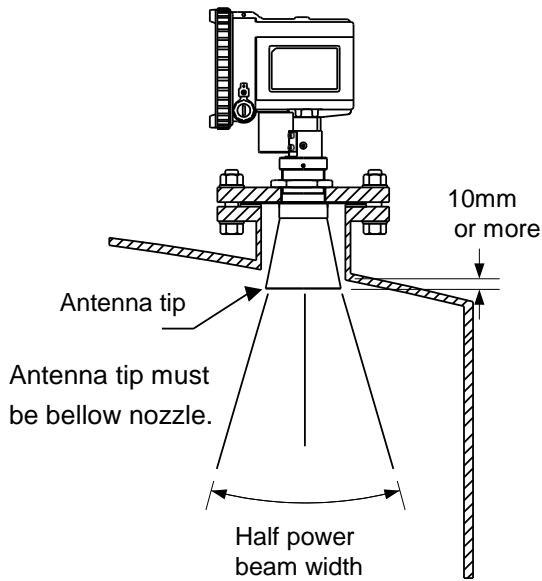

Size of microwave transmitting area

* (-3dB down angle)

| Distance (m) | Diameter (m) | | | |
|--------------|--------------|---------|---------|------|
| Antenna type | 4B Cone | 6B Cone | 8B Cone | Rod |
| Beam angle | 34° | 22° | 17° | 30° |
| 5 | 2.9 | 1.9 | 1.5 | 2.7 |
| 10 | 5.8 | 3.8 | 3.0 | 5.4 |
| 15 | 8.8 | 5.7 | 4.4 | 8.0 |
| 20 | 11.7 | 7.6 | 5.9 | 10.7 |

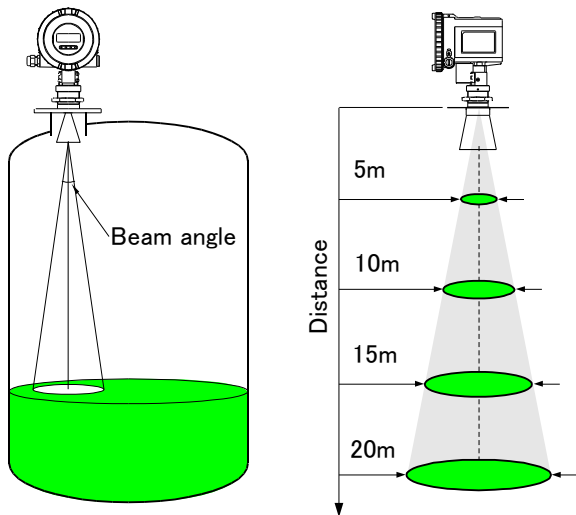

9. Electrical Installation

MRG-10 is 2-wire system, which means both signal and power are available on same wiring. The power source voltage is 16-36VDC in non-hazardous area, and 16-28VDC in hazardous area might be available. For application twisted and sealed cable is recommended.

Also, if you want to know more detail conditions, please refer installation guidance.

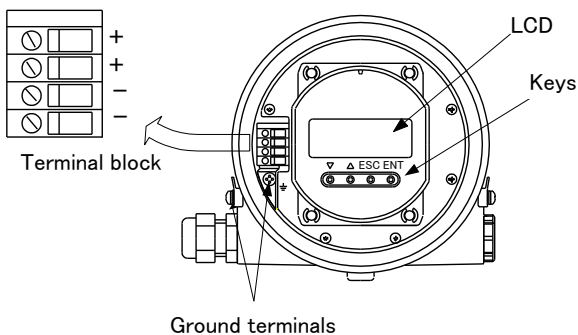

SPECIFICATIONS

| 1.General | |
|----------------------------------|--|
| Measuring principle | Time Flight impulse Radar technology |
| Operating frequency | 5.8 GHz |
| Half power beam angle | Rod antenna: 30deg., Cone antenna 4": 34deg., 6": 22deg., 8": 17deg. |
| Microwave output power | Max 1 μ W |
| Reference conditions | Free space reflection from metal surface, ambient temperature 25°C, atmospheric pressure |
| 2.Display / Configuration | |
| Local display | 5 digit LCD display with 4 configuration buttons. Level, Ullage, Volume, Current or Amplitude output |
| HART hand held communicator | Rosemount Communicator RS275, just display not for configuration |
| PC Remote configuration | Windows base setup and configuration software |
| 3.Electrical | |
| Power supply | Loop powered 16-36 VDC |
| Output | Analog DC4-20mA +HART |
| Output variable | Level, Ullage in m or ft. Volume in %, Amplitude in dB. |
| Signal on alarm | Hold, Low(3.9mA), High(22mA) |
| Cable entry | 2-M20x1.5(Applicable Cable diameter : 6.5-9.0mm) |
| 4.Mechanical | |
| Antenna | Rod antenna, Cone antenna 4", 6", 8" |
| Antenna material exposed to tank | Rod antenna: PFA and SUS(316L,ext.version) Cone antenna: 4", 6", 8" SUS(316L), PTFE, Viton |
| Antenna dimension | See page 5 and 6 |
| Housing / Enclosure | Casting Aluminum |
| Flange | On request or customer supply |
| Mass | 3.3--4.3Kg, depend on antenna size |
| Height above flange | 230 mm |
| 5.Environment Condition | |
| Max. pressure | -0.1 to 1.0MPa (-14 to 145 psi) |
| Ambient temperature | -20 to 70 °C (-40 to 158° F), LCD Display -20 to 70°C |
| Storage temperature | -40 to 80 °C (-40 to 176° F) |
| Tank inside temperature | -20 to 150 °C (-4 to 302° F) |
| Ingress protection | IP65 |
| Vibration resistance | IEC 68-2-6/1G |
| 6.Measuring Performance | |
| Instrument accuracy | +/- 10mm |
| Repeatability | +/- 1mm |
| Update interval | 1 Second |
| Measuring range | Depend on Antenna type and products nature, see diagram at page 4 |

Required parameters for Inquiry

AA. Tank Information

- 1) Tank Name : _____
- 2) Tank Q'ty : _____ tank(s)
- 3) Tank Dimension : If possible, send us DWG of tank.
 Tank Shape : Spherical, Cylindrical, Horizontal, Other (_____)
 Tank Volume : _____ m³ or _____ L
 Tank Height : _____ m Tank Diameter : _____ m
 0% Position : LV _____ m (=4mA) 100% Position : LV _____ m (=20mA)
- 4) Agitator Type : _____
- 5) Inner Obstruction : Heater coil / Baffles / Pipes / or others (_____)
- 6) Mounting Flange Rating : _____

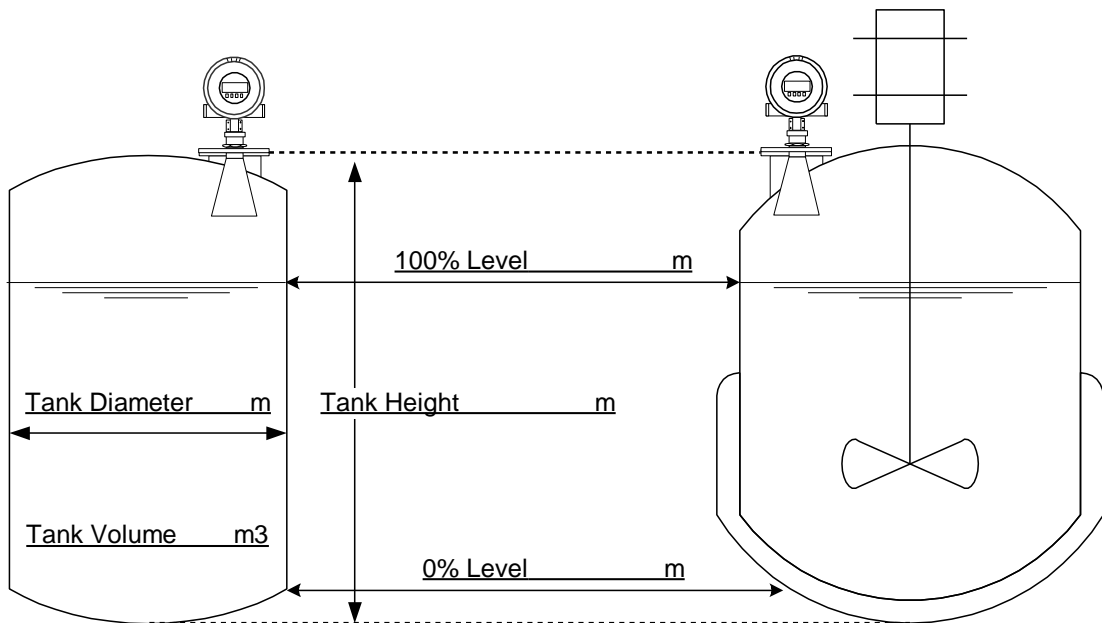

BB. Liquid Information

- 1) Liquid Name : _____ (main component)
- 2) Dielectric Constant : $\epsilon r =$ _____ (if possible)
- 3) Temperature : _____ C deg. ~ _____ C deg.
- 4) Pressure : _____ Mpa ~ _____ MPa
- 5) Corrosive Requirement : SUS316L / PFA/PTFE only
- 6) Surface Condition : Calm / Foamy / Turbulent

CC. Extra Information

- 1) Purpose of process : _____
- 2) Existing Level instruments : (if any) _____
- 3) Any other problems at Level : _____

TOKYO KEIKI INC.

2-16-46, Minami-kamata, Ohta-ku,
Tokyo 144-8551
Japan

Measurement Systems Company

Phone : +81-(0)3-3737-8664

Fax : +81-(0)3-3737-8665

JUL2020/PDS003I