

# DOPPLER SPEED LOG TD-310

## DIMENSIONS

Dimensions are reference only. Use the approved drawings for installation.

### ● Display unit MD31

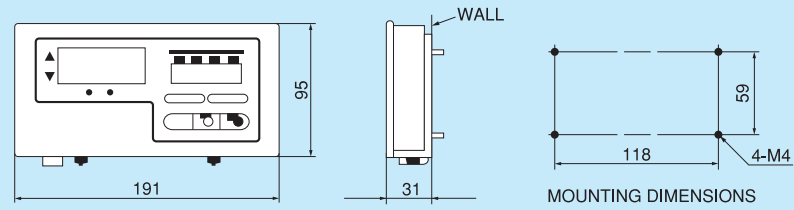

### ● Transceiver TR31

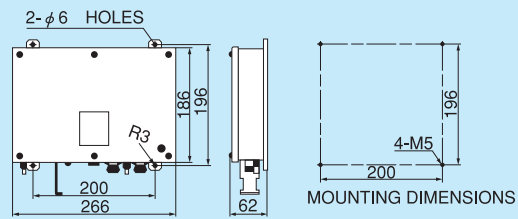

### ● Analogmeter RD55

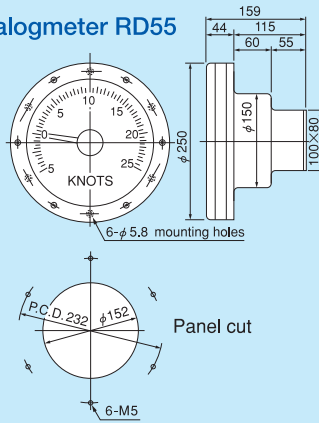

### RD56

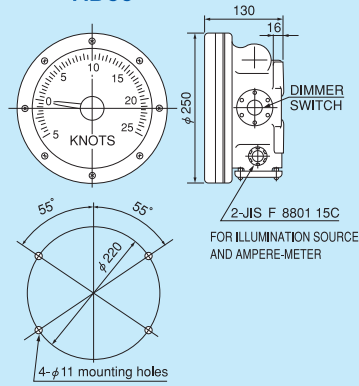

### ● Control box CB31

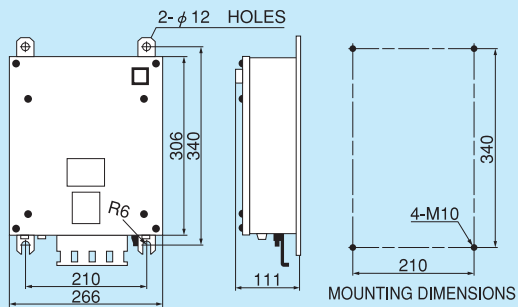

### RD57

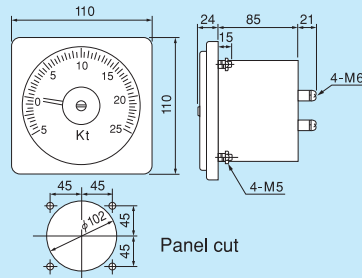

### ● Transducer Gate valve type TU51

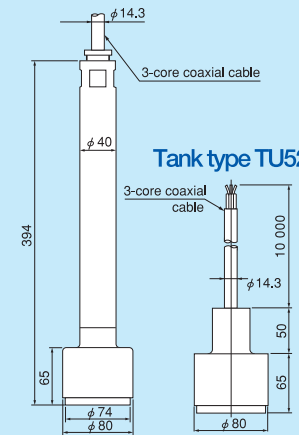

### Tank type TU52

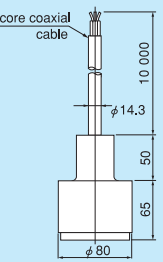

### ● Junction box JB51

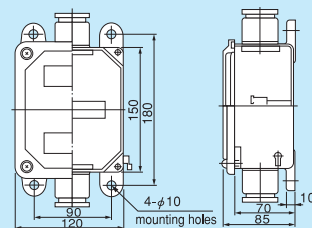

### ● Gatevalve

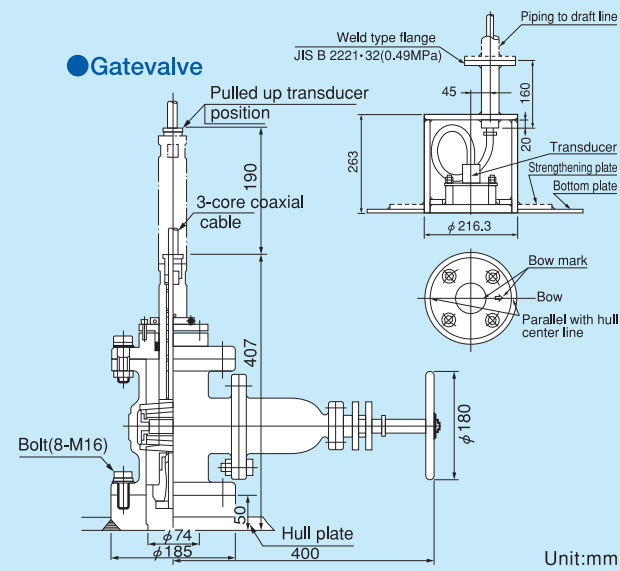

Unit:mm

Design and specifications are subject to change without prior notice, and without any obligation on the part of the manufacturer.

**CAUTION** Before operating this equipment, you should first thoroughly read the operation manual.



TOKYO KEIKI INC.

Marine Systems Company

Head Office 2-16-46, Minami-Kamata, Ohta-ku, Tokyo 144-8551 JAPAN  
 TOKYO KEIKI (SHANGHAI) CO.,LTD. C-1407, Orient International Plaza, No.85 Lou Shan Guan Rd., Shanghai 200336.CHINA  
 TOKYO KEIKI U.S.A., INC. 3452 East Foothill Boulevard, Suite420, Pasadena, CA 91107 U.S.A.  
 Singapore Branch No. 2 Jalan Rajah #07-26/28, Golden Wall Flatted Factory, Singapore 329134

[www.tokyokeiki.jp/e/products/marine/](http://www.tokyokeiki.jp/e/products/marine/)

TEL.+81-3-3737-8611 FAX.+81-3-3737-8663  
 TEL.+86-21-3223-1252 FAX.+86-21-6278-7667  
 TEL.+1-626-403-1500 FAX.+1-626-403-7400  
 TEL.+65-6254-1877 FAX.+65-6254-1745

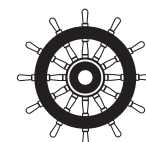

Certificate of type approval



# A high-accuracy Log complying with the requirements of IMO, Many signal output functions as standard and Easy installation.

The TD-310 Doppler Speed Log is designed in accordance with the requirements of IMO regulation and has high accuracy, many signals' output functions such as ship's speed and distance etc..

The size of units are reduced as small as possible (the display unit particularly is 1/14 in volume and 1/5 in mass compared to TD-501), and easy to install in ships such as coastal ships and ocean going ships.

## FEATURES

- The TD-310 adopts the paired-beam system in which the sonic energy is directed ahead and astern. This virtually minimizes doppler shift errors caused by the ship's motions. Furthermore, by receiving the echoes selectively from about 3 m below the ship's hull, the TD-310 minimizes adverse wake influences.
- By virtue of its non-protruding, flush-mount design, the transducer of the TD-310 is completely free from the damage caused by drift ice or wood. Moreover, it needs not to be retracted before entering a port or extended after leaving it.
- Total cumulative distance(DISTANCE 1) and distance since reset(DISTANCE 2) are memorized for each display unit.
- Up to 3 Display units and 4 Analog meters can be connected.
- Auxiliary output signals as standard
  - Digital interface (IEC-61162-1 VBW,VLW) : 8 circuits
  - 200 pulses/mile contact signals : 8 circuits
  - Current signal (4-20 mA) : 1 circuit
  - Voltage signal : 1 circuit
- Low cost and simplicity of installation
  - All special cables are supplied by TOKIMEC.
  - Size of main units are reduced and as a result, system can be installed with ease and low cost. Especially, the depth of the display unit is reduced to about 30 mm.



## COMPOSITION

※ Indicates option

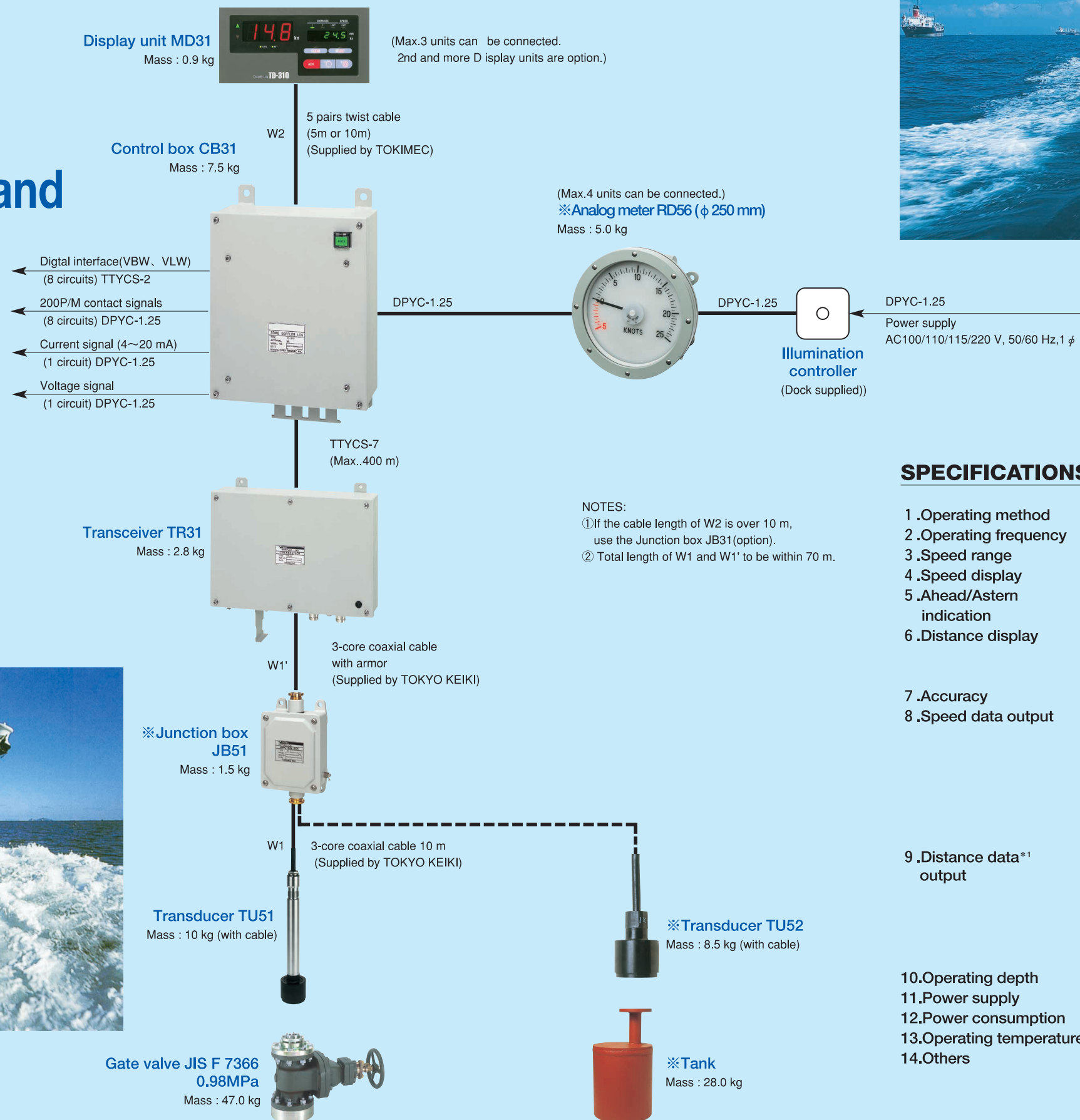

### NOTES:

- ① If the cable length of W2 is over 10 m, use the Junction box JB31(option).
- ② Total length of W1 and W1' to be within 70 m.

## SPECIFICATIONS

- |                            |   |
|----------------------------|---|
| 1 .Operating method        | Ultrasonic paired-beam pulsed doppler system  |
| 2 .Operating frequency     | 2 MHz   |
| 3 .Speed range             | -10 knots ~ +30 knots   |
| 4 .Speed display           | 3-digits numerical LED readout  |
| 5 .Ahead/Astern indication | Ahead : green LED indication<br>Astern : red LED indication   |
| 6 .Distance display        | 0.0~9999.9 nautical miles in LED<br>Distance1 and distance2 can be stored in non-volatile memory for each display unit  |
| 7 .Accuracy                | ±0.1 knot(speed) ±1 %(distance)   |
| 8 .Speed data output       | • IEC-61162-1 VBW sentence(8 circuits) output period is variable between 0.5 and 9.9 sec.<br>• Current signal(1 circuit) 4 mA = - 5 knots, 20 mA = +25 knots<br>• Voltage signal(1 circuit) -3.2 V = -10 knots, 9.6 V = +30 knots |
| 9 .Distance data*1 output  | • IEC-61162-1 VLW sentence(8 circuits) output period is variable between 0.5 and 9.9 sec.<br>*1 Distance data of No.1 display unit  |
| 10 .Operating depth        | 3 m (2m~5m variable)  |
| 11 .Power supply           | AC 100/110/115/220 V $\pm 15\%$ 50/60 Hz 1 φ  |
| 12 .Power consumption      | Less than 50 VA   |
| 13 .Operating temperature  | -15 °C ~ +55 °C   |
| 14 .Others                 | 1)Self check function<br>2)Analog meter connection<br>3)Sea water temperature automatic correction<br>4)Transducer mounting error correction  |

